

# PLOR7412CAM-KLOR7412CAM

PORTAVALIGIE LATERALE SPECIFICO - SPECIFIC TUBULAR SIDE-CASE HOLDER - PORTE-VALISES LATÉRAUX SPÉCIFIQUE  
SPEZIFISCHES STAHLROHR-SEITENTRAEGER - PORTA MALETAS LATERALES ESPECÍFICO - TRONCO LADO ESPECÍFICO

## DUCATI MULTISTRADA 950S (2019)

N°	Descrizione/Description	Caratteristiche/Features	Codice/Code	Quantità/ Quantity
1	Supporto laterale - Lateral support - Support latéral Soporte lateral - Untere Halterung - Suporte lateral	-	PLR7412DXS PLR7412SXS	2 (Right;Left)
2	Ponte Posteriore - Rear Bridge - Pont Postérieure Verbindungsrohr - Puente Trasero - Ponte Traseira	-	GNB2366V	1
3	Piastrina di supporto - Support plate Plaque de support - Trägerplatte Pletina de soporte - Placa de apoio	-	GL2919RV	1(Right Side)
4	Piastra di supporto - Support plate Plaque de support - Trägerplatte Pletina de soporte - Placa de apoio	-	GL2920RV	1(Left Side)
5	Supporto inferiore - Lower support - Support inférieur Soporte inferior - Untere Halterung - Suporte inferior	-	GL2921RV	1
6	Paracalore - Heat Guard Hitzeschutz- Pare Chaleur Protector De Calor - Protetor De Calor	-	GL4292V	1
7	Cavallotto - Retaining clamp - Patte de fixation - Abrazadera - Halteklammern - Abraçadeira de fixação	-	GNB1919V	2
8	Vite - Screw Vis - Schraube Tornillo - Parafuso	TBEI M6x50	650TBEI	4
9	Vite - Screw Vis - Schraube Tornillo - Parafuso	TCEI M8x40	840TCEI	4
10	Vite - Screw Vis - Schraube Tornillo - Parafuso	TBEI M6x30	630TBEI	2
11	Vite - Screw Vis - Schraube Tornillo - Parafuso	TBEIFN M6x10	610TBEIFN	2
12	Distanziale - Spacer Entretoise - Distanzstueck Distanciador - Espaçador	Ø16x10 Foro 6,5T	C16L10F6,5	6
13	Distanziale - Spacer Entretoise - Distanzstueck Distanciador - Espaçador	Ø16x3 Foro 6,5T	C16L3F6,5	4
14	Distanziale - Spacer Entretoise - Distanzstueck Distanciador - Espaçador	Ø14x19 Foro 6,5T	C14L19F6,5	4

# PLOR7412CAM-KLOR7412CAM

PORTAVALIGIE LATERALE SPECIFICO - SPECIFIC TUBULAR SIDE-CASE HOLDER - PORTE-VALISES LATÉRAUX SPÉCIFIQUE  
 SPEZIFISCHES STAHLROHR-SEITENTRAEGER - PORTA MALETAS LATERALES ESPECÍFICO - TRONCO LADO ESPECÍFICO

## DUCATI MULTISTRADA 950S (2019)

N°	Descrizione	Caratteristiche	Codice	Quantità
15	Rondella - Washer Rondelle - Scheibe Arandela - Arruela	Foro Ø8,5mm/ Esterno Ø20mm Spessore 2mm	820RON	2
16	Rondella spaccata - Split washer Scheibe - Rondelle fendue Arandela seccionada - Arruela Dentada	Ø6mm	Z1063	4
17	Rondella - Washer Rondelle - Scheibe Arandela - Arruela	Foro Ø9mm/ Esterno Ø32mm Spessore 2mm	832RON	2
18	Dado - Bolt - Erou Mutter - Tuerca - Porca	Auto Bloccante Metalblock Flangiato Ribassato M6 (H. 6mm)	6DADIAFL	2
19	Protezione Adesiva - Adhesive Protection - Protection Adhesive - Schutzkleber - Protecção Adesiva	-	Z298	1
20	Boccola - Mounting bush Entretoise de montage - Cilindro de fijación Montagehülse - Bucha de fixação	-	Z2379	2
21	Distanziale - Low Spacer Bas Entretoise - Niedriger Distanzstueck Distanciador Bajo - Baixo Espaçador	-	V064	2
22	Protezione Adesiva - Adhesive Protection - Protection Adhesive - Schutzkleber - Protecção Adesiva	-	Z2388	2
23	Chiave Per Viti A Testa Speciale Special Key - Cle Speciale Spezialschlüssel Zur Demontage Des Trägers Llave Para Tornillos Con Cabeza Especial	-	PLXRC	1
24	Componenti Originali - Original Parts Parties Originales - Original Bauteile Componentes Originales - Componentes Originais	-	-	-

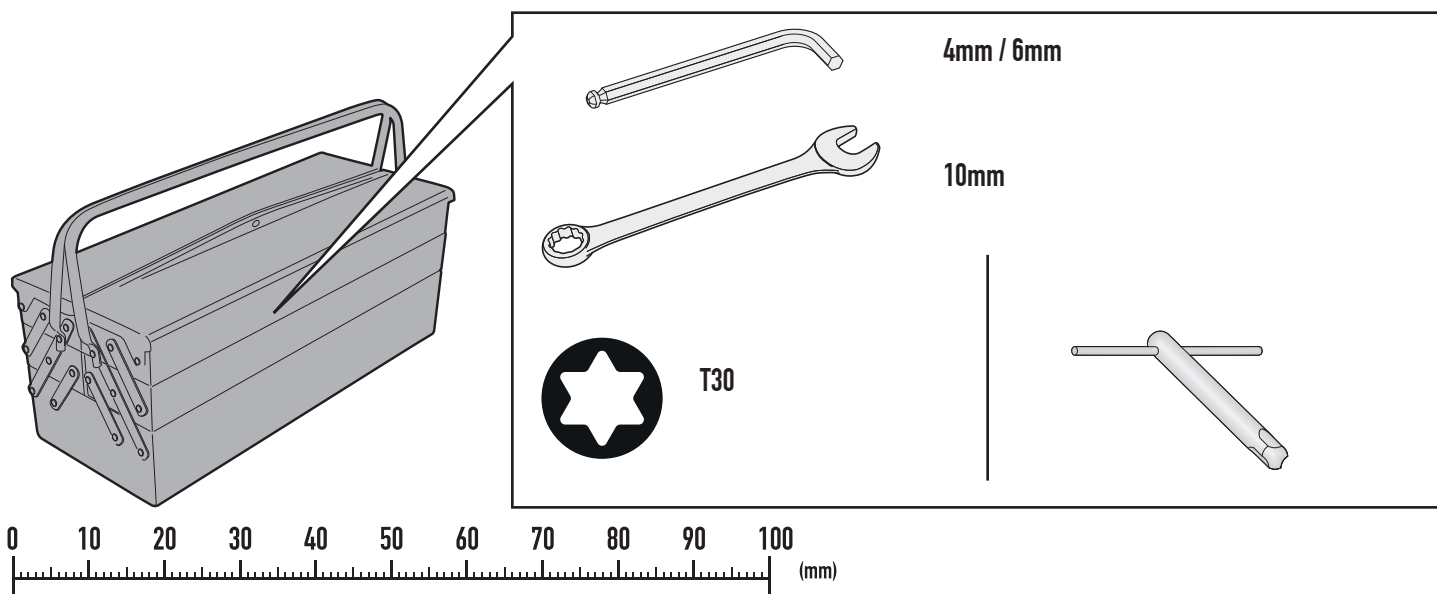

ISTRUZIONI DI MONTAGGIO - MOUNTING INSTRUCTIONS  
 INSTRUCTIONS DE MONTAGE - BAUANLEITUNG  
 INSTRUCCIONES DE MONTAJE - INSTRUÇÕES DE MONTAGEM

# PLOR7412CAM-KLOR7412CAM

PORTAVALIGIE LATERALE SPECIFICO - SPECIFIC TUBULAR SIDE-CASE HOLDER - PORTE-VALISES LATÉRAUX SPÉCIFIQUE  
SPEZIFISCHES STAHLROHR-SEITENTRAEGER - PORTA MALETAS LATERALES ESPECÍFICO - TRONCO LADO ESPECÍFICO

## DUCATI MULTISTRADA 950S (2019)

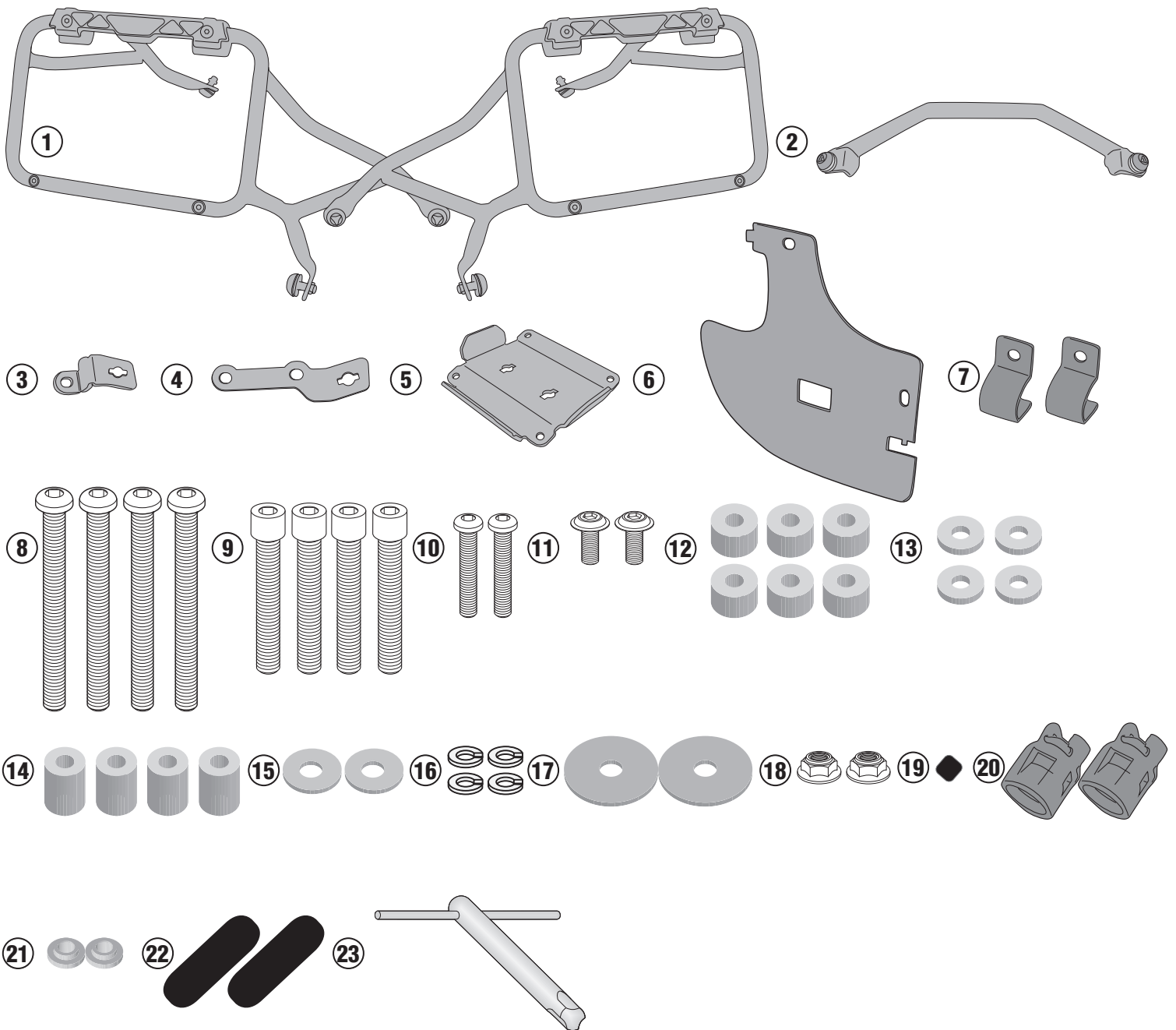

# PLOR7412CAM-KLOR7412CAM

PORTAVALIGIE LATERALE SPECIFICO - SPECIFIC TUBULAR SIDE-CASE HOLDER - PORTE-VALISES LATÉRAUX SPÉCIFIQUE  
SPEZIFISCHES STAHLROHR-SEITENTRAEGER - PORTA MALETAS LATERALES ESPECÍFICO - TRONCO LADO ESPECÍFICO

## DUCATI MULTISTRADA 950S (2019)

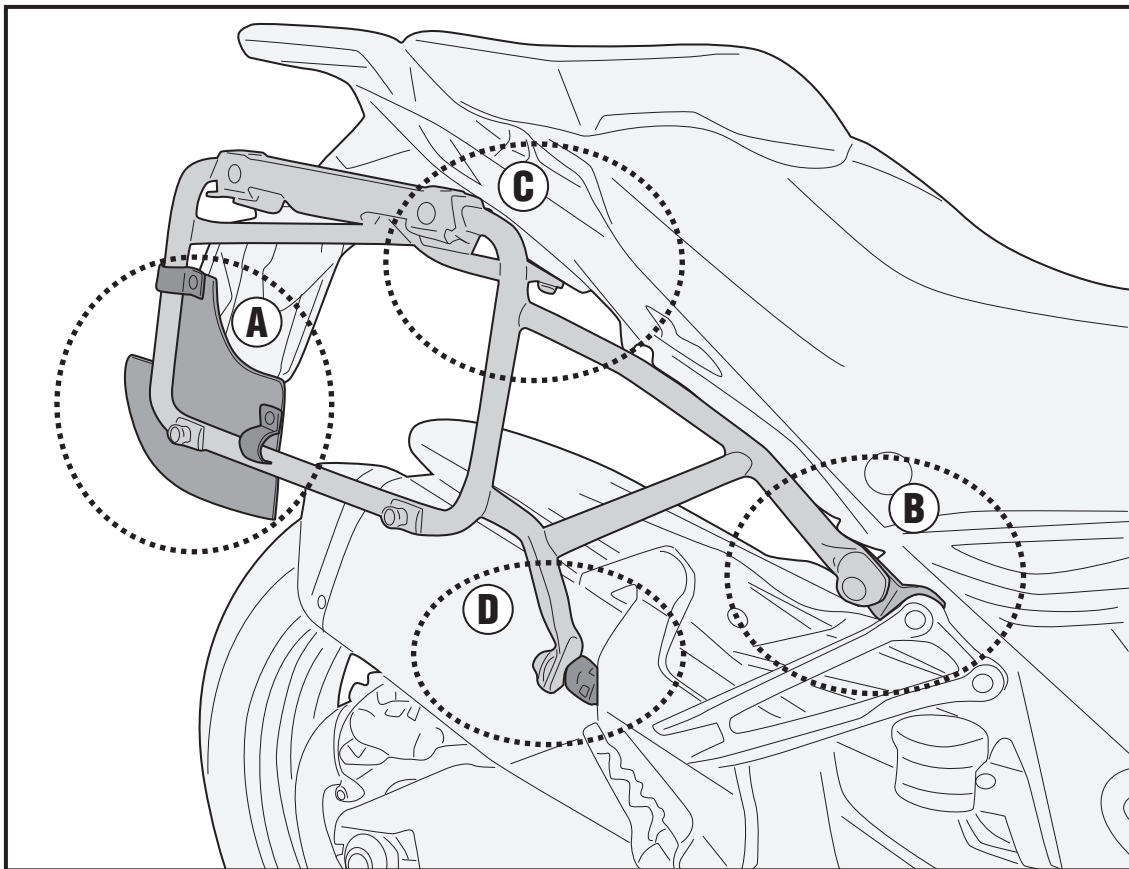

RIGHT SIDE

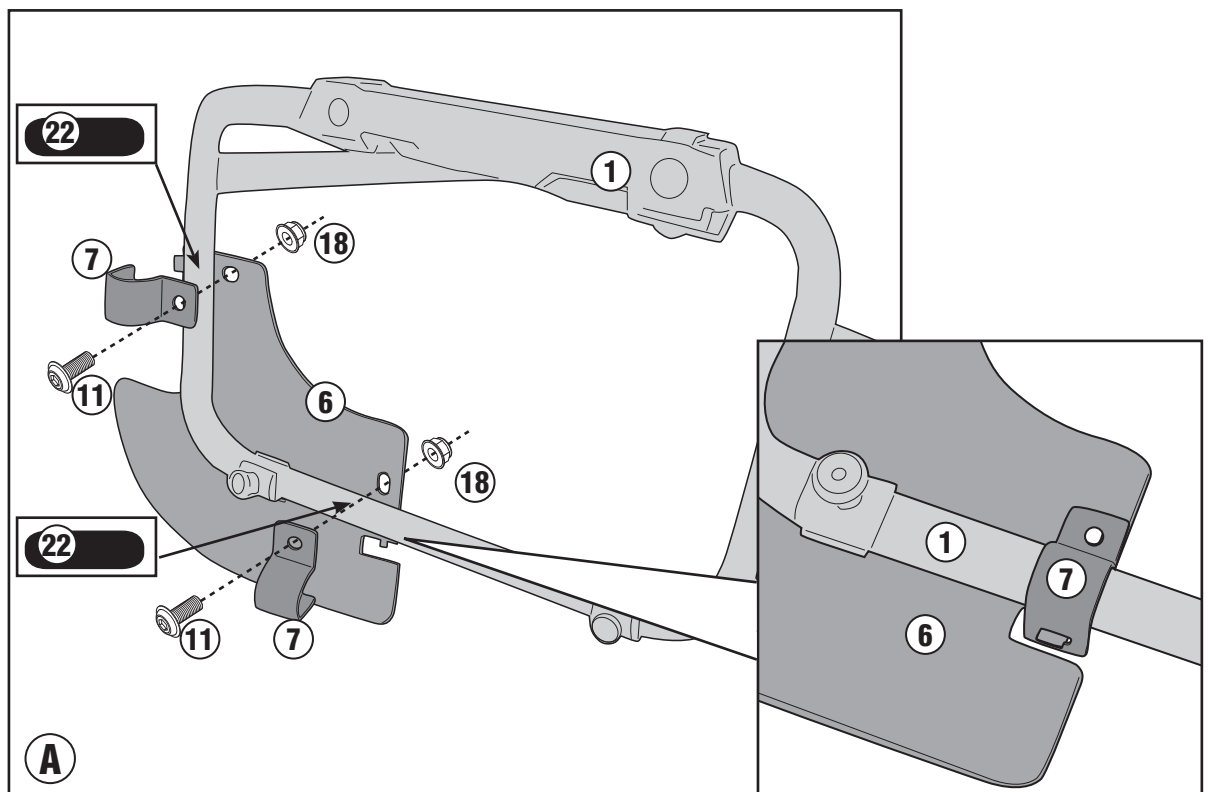

ISTRUZIONI DI MONTAGGIO - MOUNTING INSTRUCTIONS  
INSTRUCTIONS DE MONTAGE - BAUANLEITUNG  
INSTRUCCIONES DE MONTAJE - INSTRUÇÕES DE MONTAGEM

# PLOR7412CAM-KLOR7412CAM

PORTAVALIGIE LATERALE SPECIFICO - SPECIFIC TUBULAR SIDE-CASE HOLDER - PORTE-VALISES LATÉRAUX SPÉCIFIQUE  
SPEZIFISCHES STAHLROHR-SEITENTRAEGER - PORTA MALETAS LATERALES ESPECÍFICO - TRONCO LADO ESPECÍFICO

## DUCATI MULTISTRADA 950S (2019)

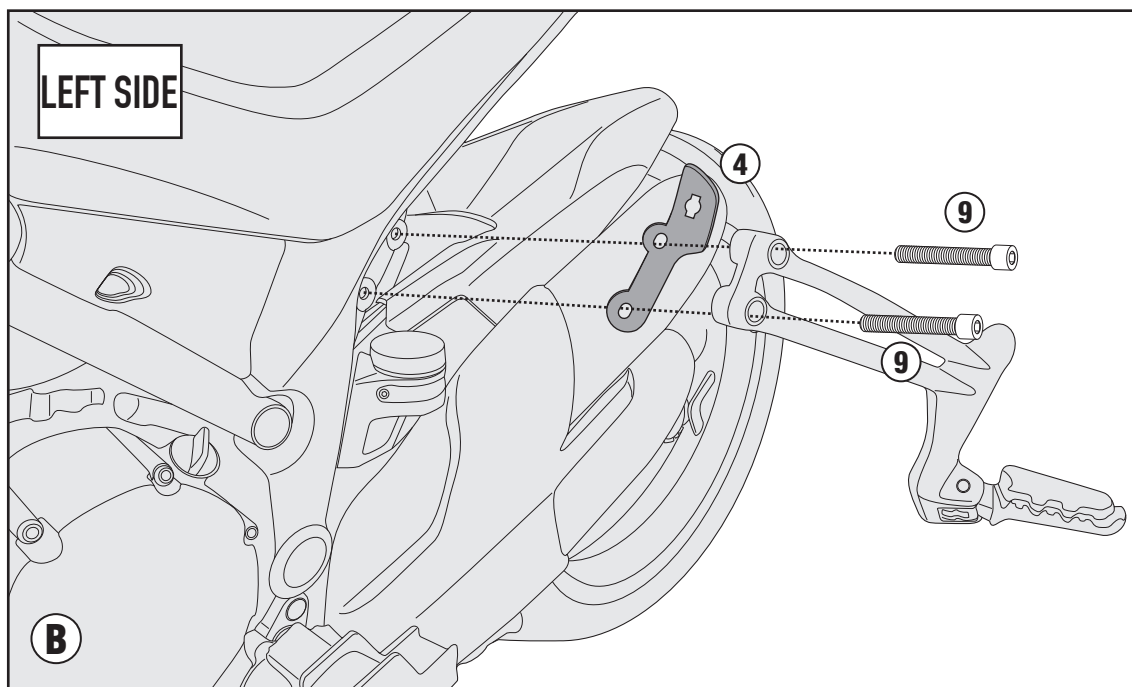
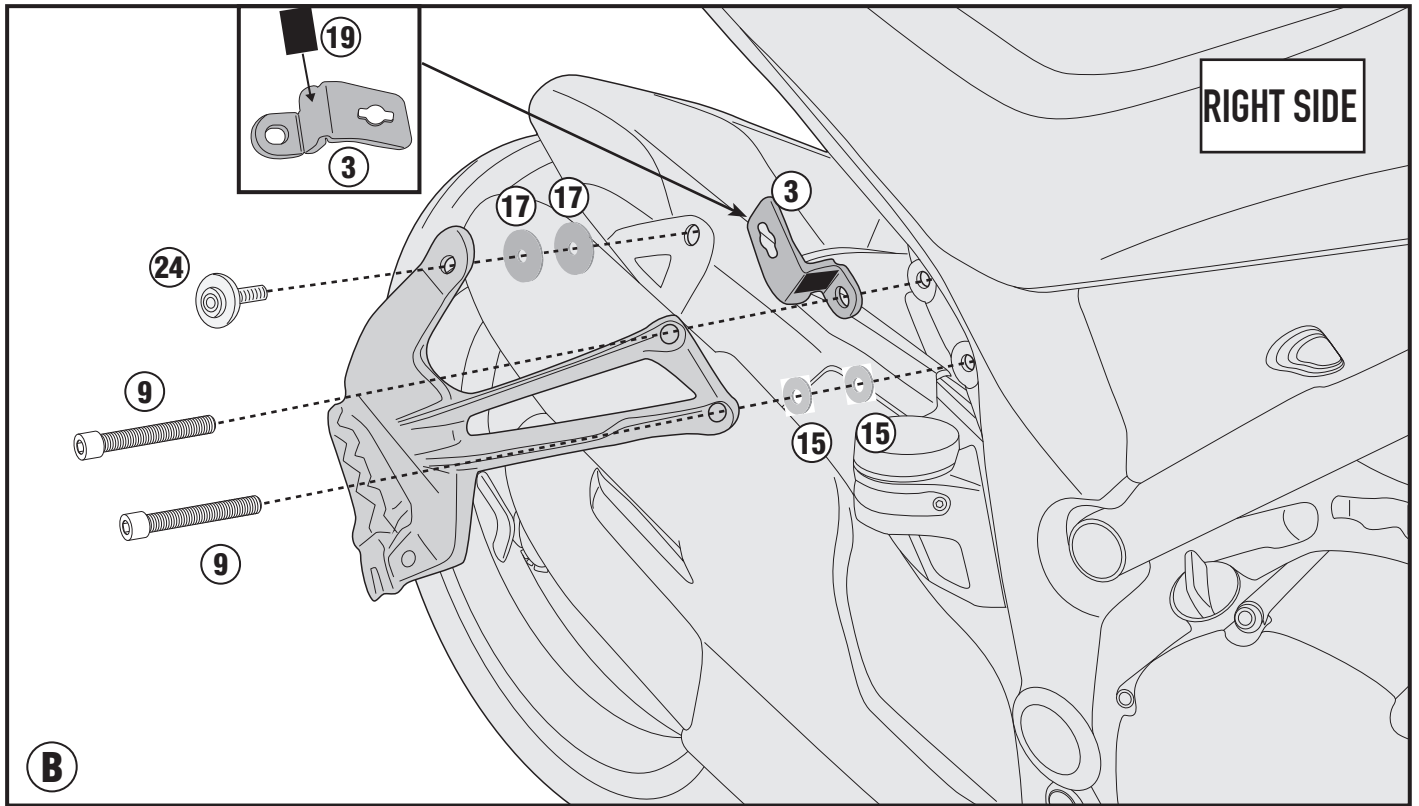

# PLOR7412CAM-KLOR7412CAM

PORTAVALIGIE LATERALE SPECIFICO - SPECIFIC TUBULAR SIDE-CASE HOLDER - PORTE-VALISES LATÉRAUX SPÉCIFIQUE  
SPEZIFISCHES STAHLROHR-SEITENTRAEGER - PORTA MALETAS LATERALES ESPECÍFICO - TRONCO LADO ESPECÍFICO

## DUCATI MULTISTRADA 950S (2019)

### ONLY PLOR7412CAM

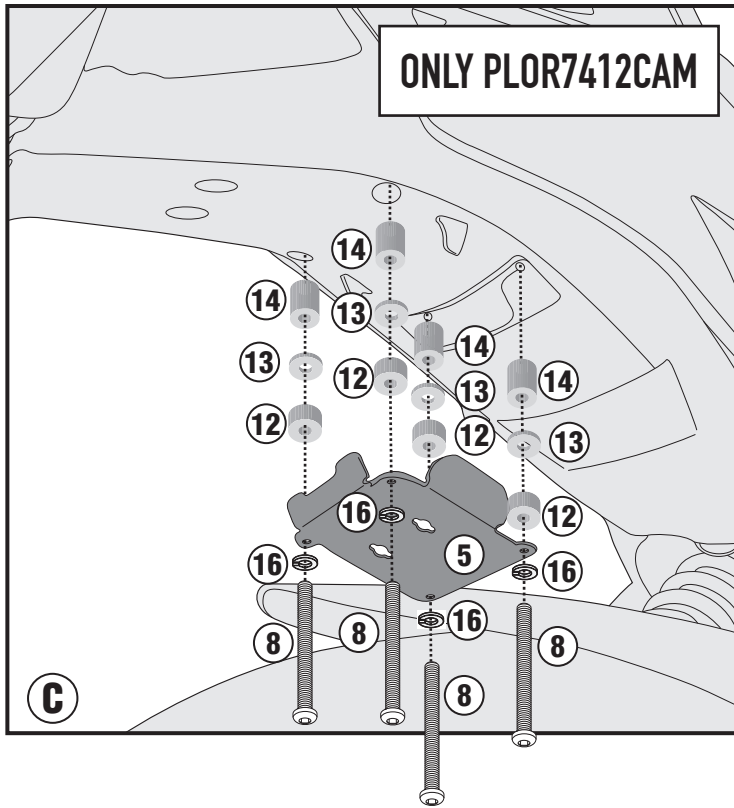

### PLOR7412CAM+ORIGINAL RACK

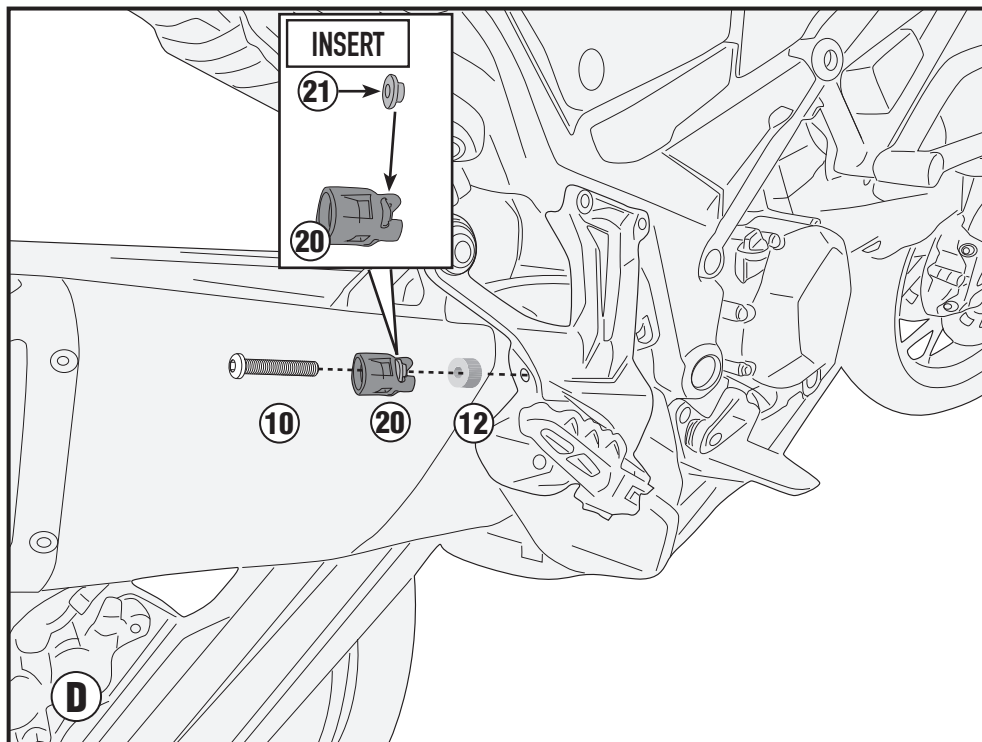
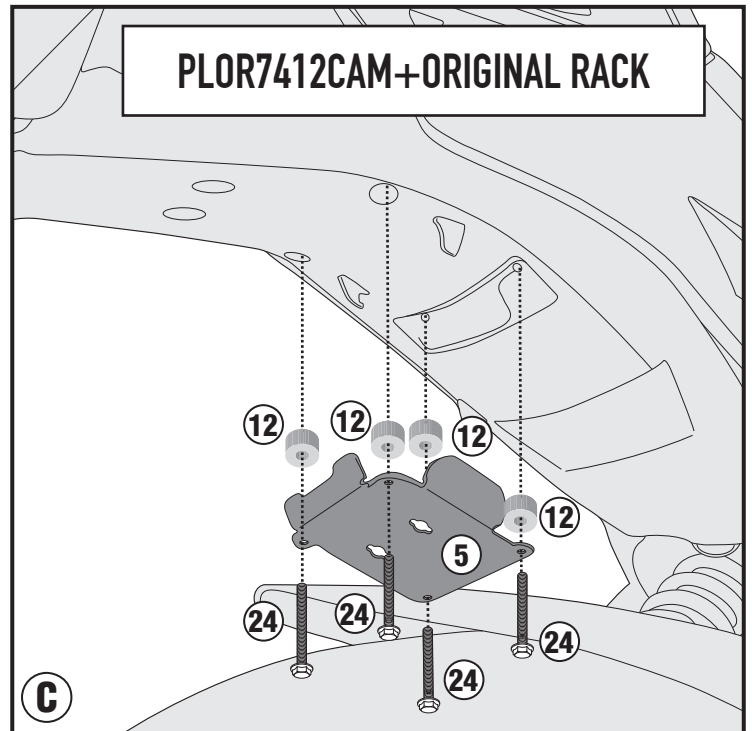

# PLOR7412CAM-KLOR7412CAM

PORTAVALIGIE LATERALE SPECIFICO - SPECIFIC TUBULAR SIDE-CASE HOLDER - PORTE-VALISES LATÉRAUX SPÉCIFIQUE  
SPEZIFISCHES STAHLROHR-SEITENTRAEGER - PORTA MALETAS LATERALES ESPECÍFICO - TRONCO LADO ESPECÍFICO

## DUCATI MULTISTRADA 950S (2019)

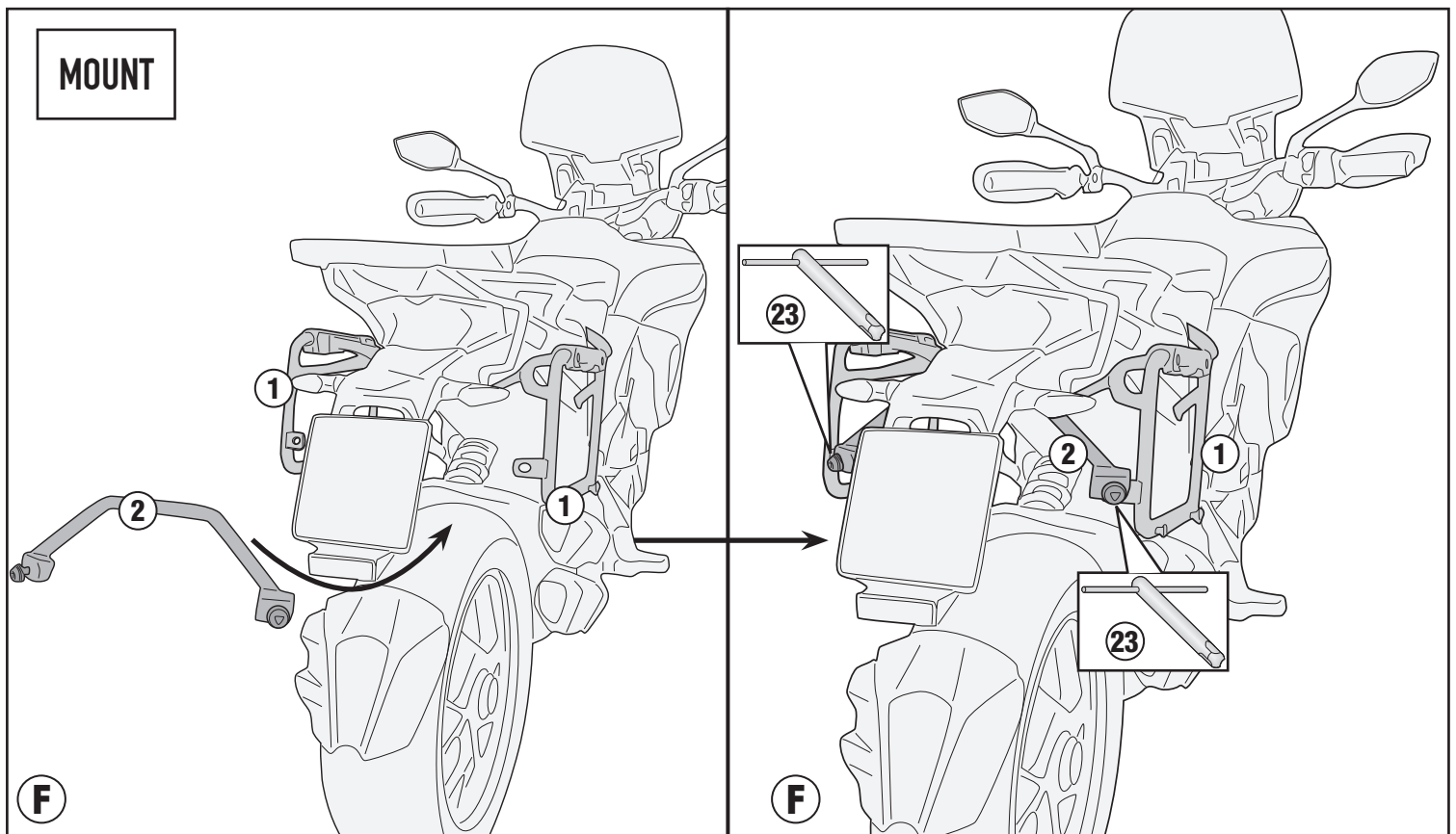
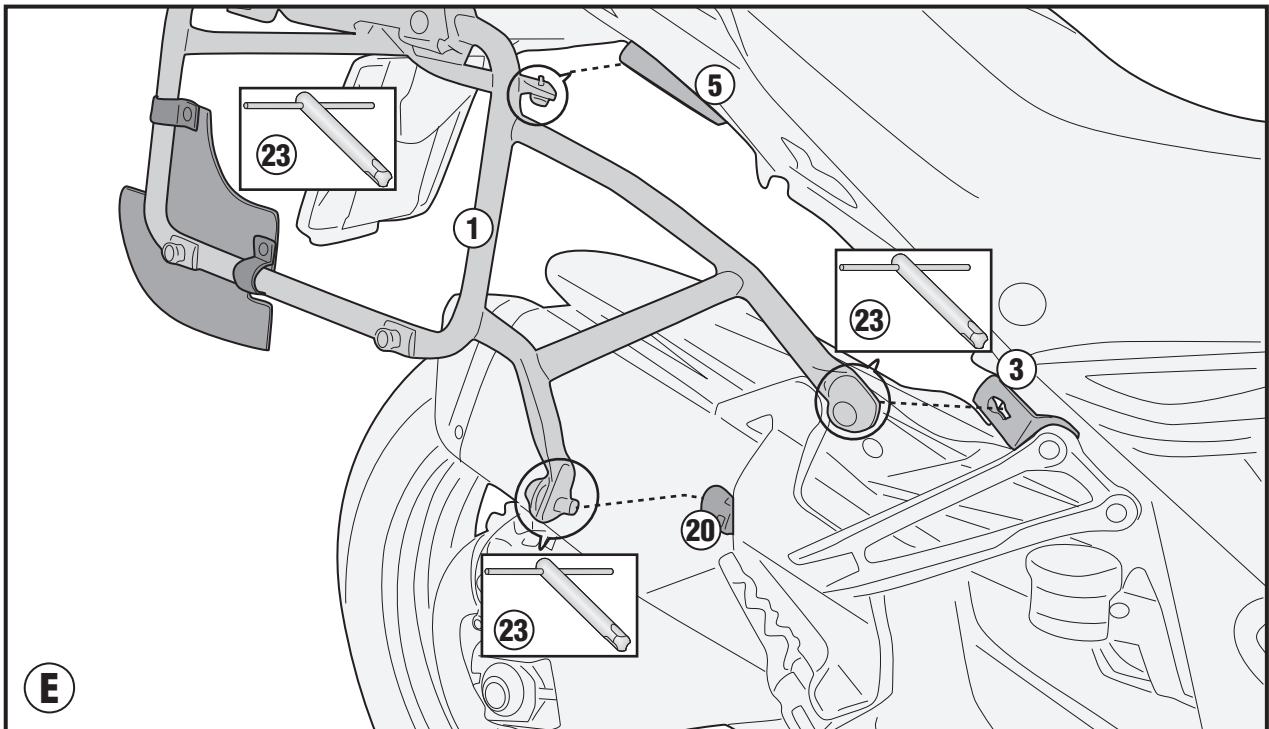

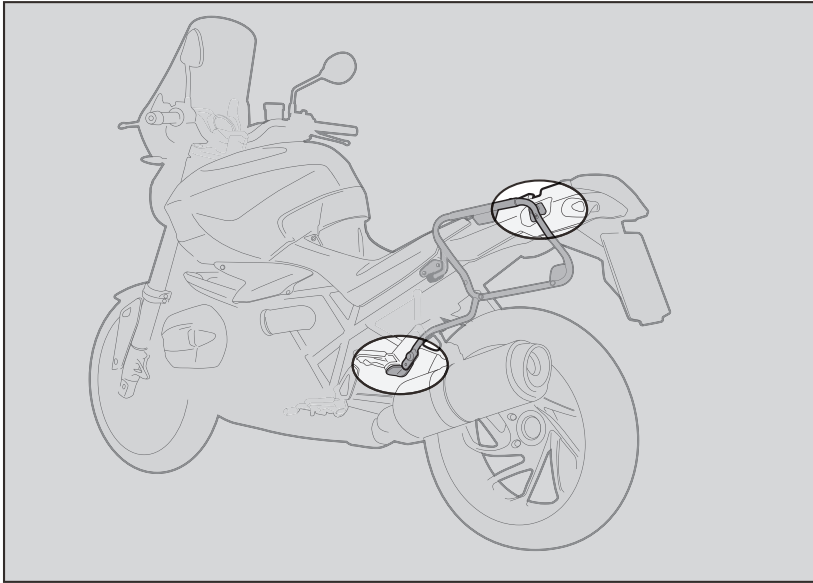

1. INSERIRE L'ATTREZZO NELLA TESTA DELLA VITE SPECIALE;
2. RUOTARE DI 1/4 DI GIRO IN SENSO ORARIO FINO A CHE LA ROTAZIONE NON TERMINA E SI AVVERTE LO SCATTO;
3. PER SMONTARE PROCEDERE IN SENSO INVERSO.

1. INSERT THE SPECIAL KEY INTO THE HEAD OF THE SCREW;
2. TURN THE KEY ¼ TURN CLOCKWISE UNTIL ROTATION STOPS AND THE SIDE CASE HOLDER IS FASTENED SECURELY TO THE FITMENT POINT;
3. IN ORDER TO DISASSEMBLE THE BRACKETRY PERFORM THE OPERATION IN REVERSE.

1. INSERER LA CLE SPECIALE DANS LA TÊTE DE LA VIS;
2. VISSER D'1/4 DE TOUR DANS LE SENS HORAIRE JUSQU'AU BLOCAGE DE LA VIS POUR MONTER EN TOUTE SECURITE LE SUPPORT A SON POINT DE FIXATION;
3. POUR LE DEMONTAGE, PROCEDER EN SENSE INVERSE.

1. STECKEN SIE DAS WERKZEUG IN DEN KOPF DER SPEZIFISCHEN SCHRAUBE;
2. DREHEN SIE DIE SCHRAUBE 1 / 4 UMDREHUNG IM UHRZEIGERSINN BIS SIE BEMERKEN, DASS DIE SCHRAUBE IM BEFESTIGUNGSPUNKT EINGEKLEMMT IST;
3. FÜR DIE DEMONTAGE FOLGEN SIE DEN HINWEISE UMGEKEHRT.

1. INSERTAR LA LLAVE ESPECIAL EN LA CABEZA DEL TORNILLO
2. DAR ¼ DE VUELTA EN EL SENTIDO HORARIO HASTA QUE LLEGUE AL TOPE Y SE VEA EL TORNILLO;
3. PARA DESMONTARLO PROCEDER EN LA DIRECCIÓN CONTRARIA;

**MONTAGGIO - ASSEMBLY - MONTAGE - MONTAGE - MONTAJE**

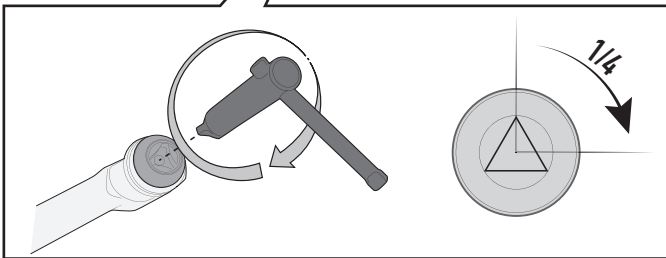
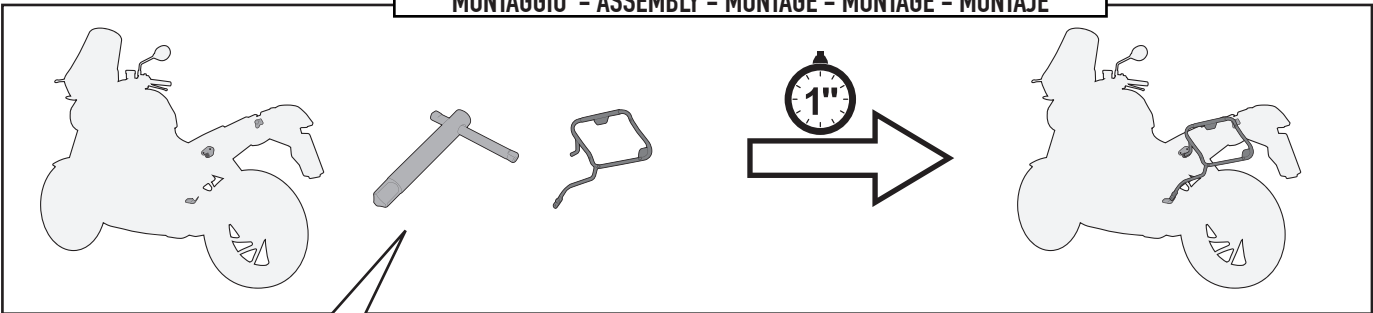

**SMONTAGGIO - DISASSEMBLY - DÉMONTAGE - DEMONTAGE - DESMONTAJE**

